

30 Watt Universal 2-Wire Input Adapter

Meets CEC and 2007 Energy Independence Security Act

NetBit®

www.NetBit.com



Features

- Low Cost
- Slim Low Profile Design
- Class B EMI
- No Load Power Consumption <0.5W
- Slim Low Profile Design
- Efficiency Level IV Compliant

Applications

- Access Devices
- Peripherals
- Net Books
- Networking
- Portable Equipment

Safety Approvals

- cUL/UL EN60950-1
- CE
- TUV EN60950-1

Mechanical Characteristics

- Length: 103mm
- Width: 50mm
- Height: 17mm
- Weight: 160g

Output Specifications

Model	DC Output Voltage	Load		Ripple (1) P-P (max)	Regulation		Efficiency Level
		Min.	Max.		Line	Load	
KSUS 0301200250M2	+12V	0.0A	2.50A	200mV	±5%		IV

(1) Measured by pass capacitors 0.1uF/ 100uF at output connector terminal and oscilloscope set at 20 Mhz

NetBit reserves the right to make changes without further notice. Please consult NetBit and visit www.netbit.com for the most up to date specifications.

INPUT:

AC Input Voltage Rating

100-240 VAC

AC Input Voltage Range

90 to 264 VAC

AC Input Frequency

47/63 Hz

Input Current

1.6A @ 100VAC

0.8A @ 240VAC

Leakage Current

3.5mA Max. @254VAC 60Hz

Inrush Current (cold)

90A Max @ 100VAC

150A Max. @ 240VAC

(Cold start at ambient 25° C)

Input Power Saving

<0.5W at no load

OUTPUT:

Efficiency

79% minimum average efficiency

Hold-up time

>10mS

Over-current Protection

Circuit will latch

Short Circuit Protection

Auto-reset when short is removed

ENVIRONMENTAL:

Temperature

Operation 0°C to +40°C

Non-operation -20°C to +80°C

Humidity

Operation 5% to 90%

Emissions

FCC Class B

EN55022 Class B

RELIABILITY:

MTBF 50k Hr. @ ambient 25°C

DC Output Connector

2.5 x 5.5mm Center Positive

Dimension Diagram Unit: mm

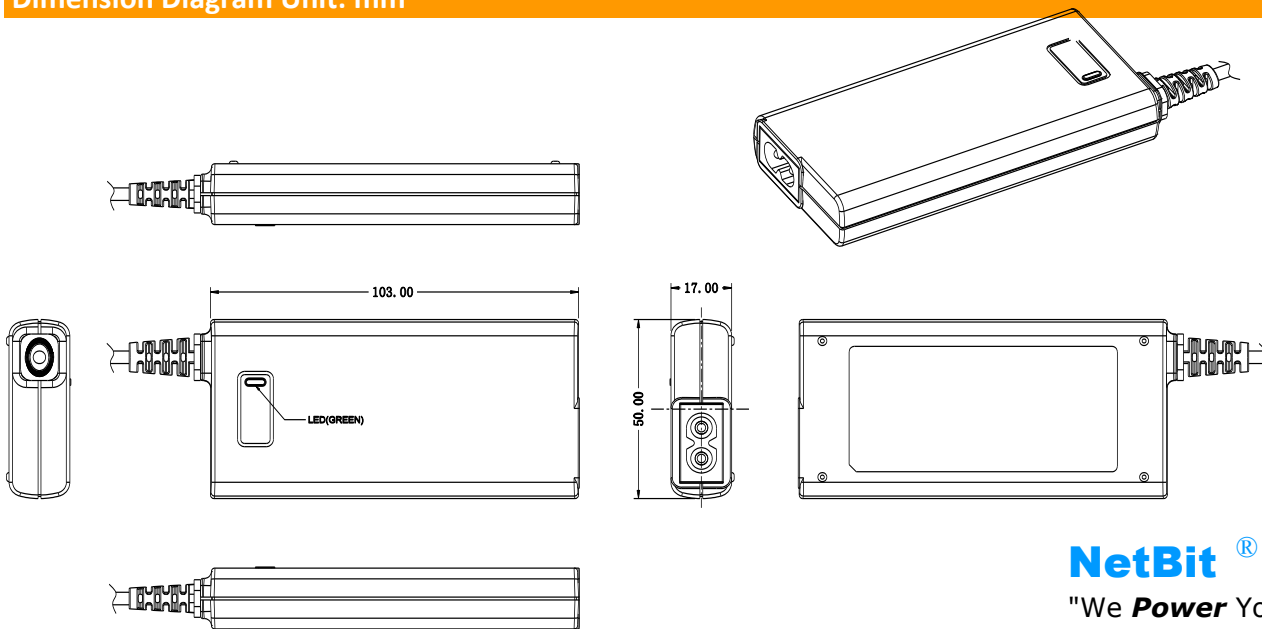

NetBit®
"We **Power** Your Idea"